

### ■ 外形寸法(mm) / Dimensions(mm)

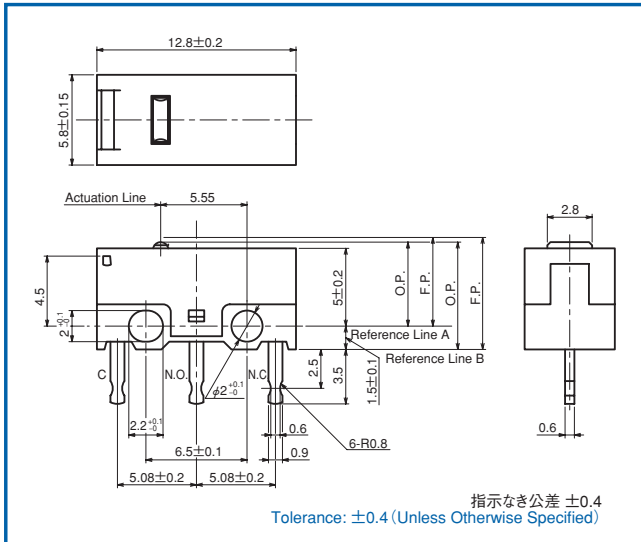

### ■ 安全規格 / Agency Approvals

シリーズ名	DG1	DG2	DG4
UL	適用規格	UL1054	
	File No.	変更申請中	

### 【特長】 [Features]

- 極超小型
- 銀合金十金メッキ接点
- 標準、軽作動の2種類の動作力。
- Ultra compact size (12.8×5.8×6.5mm)
- Insertion molded terminals: printed circuit mountable.

### ■ 取得規格 / Agency Approved



### ■ 定格 / Rating

Model	UL, CUL	Rating
DG1	UL, CUL	3A, 125VAC 2A, 30VDC
DG2	UL, CUL	50mA, 30VDC
DG4	UL, CUL	1A, 125VAC 1A, 30VDC
DG6	安全規格認定なし Non Approved	3A, 125VAC 2A, 30VDC

### ■ 性能 / Performance

項目	性能
回路構成 Circuitry	単極双投 S. P. D. T.
耐熱性 Heat Resistance	UL94V-0
接触抵抗 Contact Resistance	50mΩ 以下 50mΩ MAX
機械的寿命 Mechanical Life	DG1 1,000,000回以上 / 1,000,000 Cycles MIN DG2 1,000,000回以上 / 1,000,000 Cycles MIN DG4 1,000,000回以上 / 1,000,000 Cycles MIN DG6 1,000,000回以上 / 1,000,000 Cycles MIN
電氣的寿命 Electrical Life	DG1 (AC定格) 10,000回以上 / 10,000 Cycles MIN DG1 (DC定格) 30,000回以上 / 30,000 Cycles MIN DG2 (DC定格) 200,000回以上 / 200,000 Cycles MIN DG4 (AC定格) 10,000回以上 / 10,000 Cycles MIN DG4 (DC定格) 10,000回以上 / 10,000 Cycles MIN DG6 (AC定格) 10,000回以上 / 10,000 Cycles MIN DG6 (DC定格) 30,000回以上 / 30,000 Cycles MIN
安全規格上の電氣的寿命 Agency Approved Life	UL/CUL 6,000回 (DG1, DG2, DG4のみ)
使用温湿度範囲 Temperature Rating Range	-25 ~ +85°C 85%RH以下 (ただし結露なきこと) -25 ~ +85°C 85%RH Below (Non Condensation)
絶縁抵抗 Insulation Resistance	端子相互間: 100MΩ 以上 (DC500V) Between terminals: 100MΩ Min (DC500V) 対アース間: 100MΩ 以上 (DC500V) Between terminals and grounded parts: 100MΩ Min (DC500V)
耐電圧 Dielectric Strength	端子相互間: AC1000V 1分間 Between terminals: AC1000V 1 minute 対アース間: AC1500V 1分間 Between terminals and grounded parts: AC1500V 1 minute
耐振性 Vibration Proof	10~55Hz 全振幅1.5mm 10~55Hz Peak to peak amplitude
耐衝撃性 Shock Proof	294m/s <sup>2</sup> (30G)
最小使用電流電圧範囲 Minimum Current Voltage Range	DG1 0.05A, 5VDC または0.01A, 12VDC DG2 1mA, 5VDC DG4 1mA, 5VDC DG6 1mA, 5VDC

### ■ 材質 / Material

(難燃性 / Frame-Retardant)

部材	材質	規格
ベース Base	PPS樹脂、DG6のみPBT樹脂 (PPHS)、DG6(PBTP)	UL94V-0
カバー Cover	PBT樹脂 (PBTP)	UL94V-0
ボタン Button	PBT樹脂 (PBTP)	UL94V-0
ブレード Blade	ベリリウム銅 Beryllium copper	
端子 Terminal	黄銅(銀メッキ) Brass (Silver plated)	
接点 Contact	銀合金十金メッキ Silver alloy + Gold plated	
アクチュエータ Actuator	ステンレス Stainless steel POM樹脂(ローラー) POM (Roller)	

# DG シリーズ DG Series

## ■ 品名構成表 / Ordering Information

DG 1 3 - B 1 A A

コード Code	定格 Rating
1	3A, 125VAC 2A, 30VDC
2	0.05A, 30VDC
4	1A, 125VAC 1A, 30VDC
6	3A, 125V AC 2A, 30V DC 安全規格認定なし Non approved.

コード Code	回路構成 Circuitry
1 or A	N.O
2 or B	N.C
3 or C	N.O/N.C

コード Code	動作力 OF
B	標準 / Standard
C	軽作動 / Light

コード Code	端子形状 Terminal Configuration
1	PCB
2	PCBライト / PCB Right
3	PCBレフト / PCB Left

コード Code	コード Code	アクチュエータ長 Auxiliary Actuator-length			
		A	B	C	D
ボタン Button	A				
レバー Lever	L	4.35	12.7	25.7	
ローラー Roller	R	1.4			

アクチュエータ長  
Actuator-length

動作位置  
at Operating Point

## ■ 端子形状図 / Terminals

PCB

PCBライト / PCB Right

PCBレフト / PCB Left

指示なき公差 ±0.4  
Tolerance: ±0.4 (Unless Otherwise Specified)

## ■ 取付寸法図 / PCB Footprint

・プリント基板加工寸法

・取り付け穴加工寸法

## ■ 適用電流電圧範囲 / Current Voltage Range

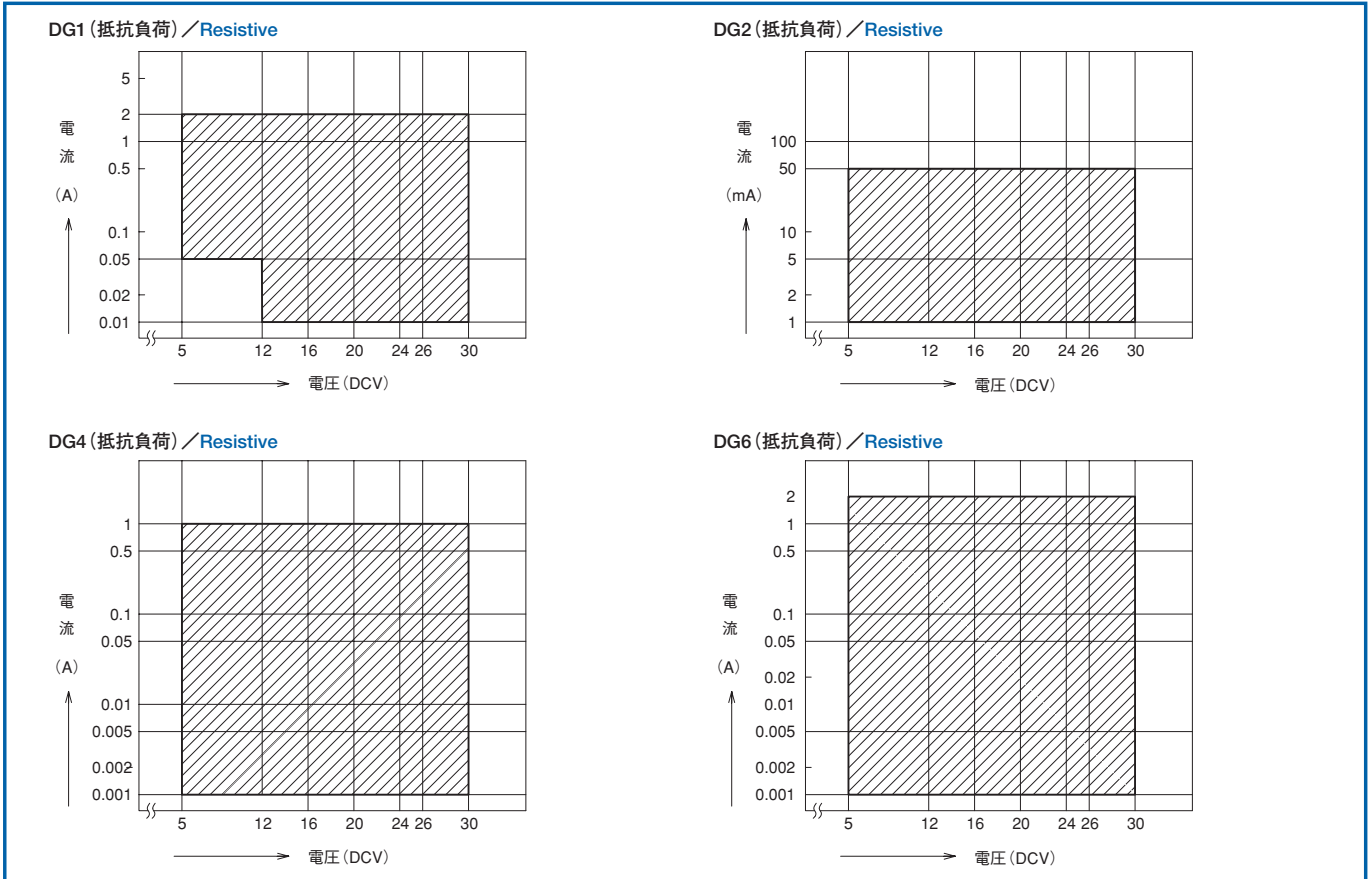

## ■ 動作特性 / Operating Characteristics

	OF	PT	OP※	OT	MD	FP※
DG□□-B□AA	137cN Max.	0.5mm Max.	5.4 ±0.2mm	0.2mm Min.	0.1mm Max.	5.7 ±0.2mm
DG□□-B□LA	44.1cN Max.	1.8mm Max.	6.8 +0.8/-0.4mm	0.55mm Min.	0.5mm Max.	8 +1.4/-0.7mm
DG□□-B□RA	58.98cN Max.	1.5mm Max.	12.4 ±0.5mm	0.55mm Min.	0.5mm Max.	13.4 ±0.5mm
DG□□-C□AA	73.5cN Max.	0.5mm Max.	5.4 ±0.2mm	0.2mm Min.	0.1mm Max.	5.7 ±0.2mm
DG□□-C□LA	29.4cN Max.	1.8mm Max.	6.8 +0.8/-0.4mm	0.55mm Min.	0.5mm Max.	8 +1.4/-0.7mm
DG□□-C□RA	34.3cN Max.	1.5mm Max.	12.4 ±0.5mm	0.55mm Min.	0.5mm Max.	13.4 ±0.5mm

注1、※印はReference Line (A) からの距離 / Distance from Reference Line (A)

## ■ 外形寸法 (mm) / Dimensions (mm)

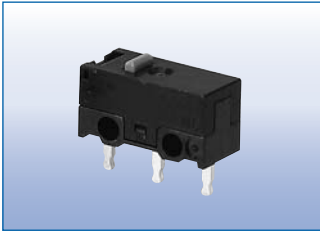
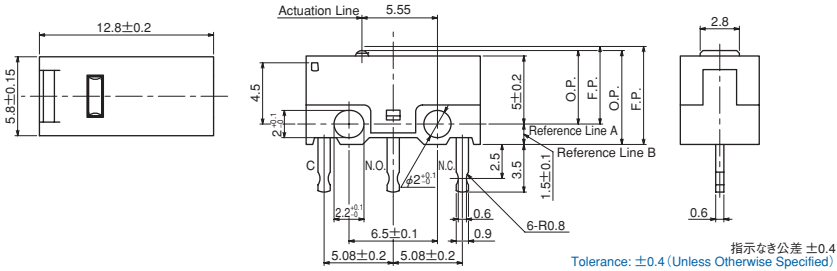
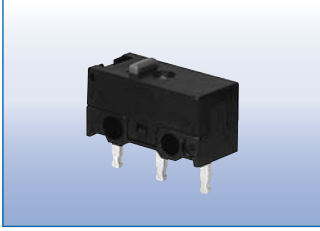
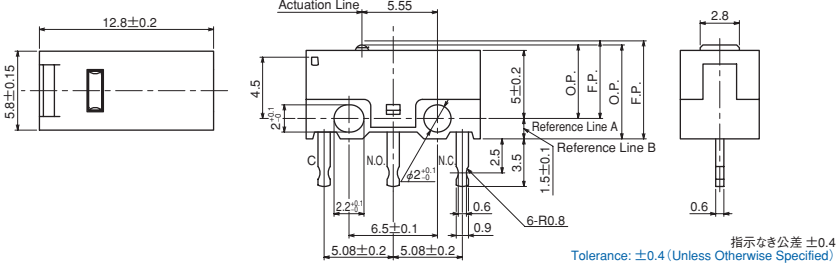
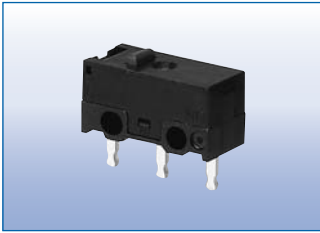
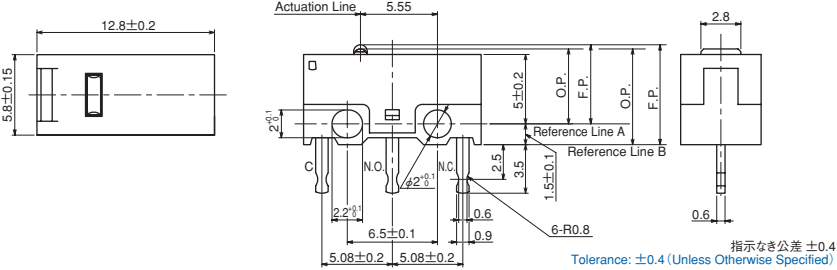
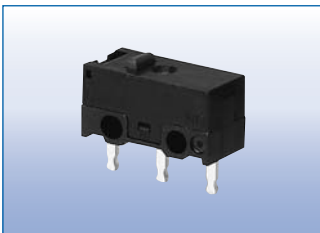
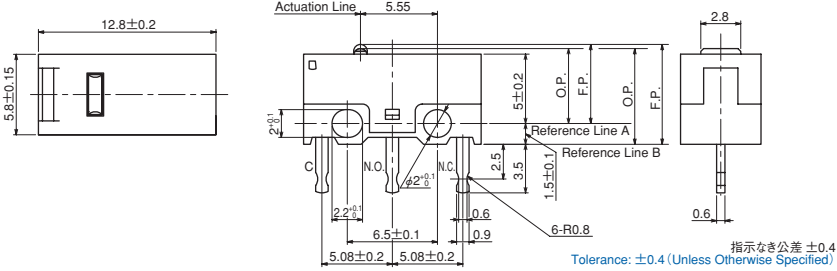
形名及び型番 Type	寸法図 Dimensions
DG23-B1AA 	 指示なき公差 ±0.4 Tolerance: ±0.4 (Unless Otherwise Specified)
DG13-B1AA 	 指示なき公差 ±0.4 Tolerance: ±0.4 (Unless Otherwise Specified)
DG43-C1AA 	 指示なき公差 ±0.4 Tolerance: ±0.4 (Unless Otherwise Specified)
DG23-C1AA 	 指示なき公差 ±0.4 Tolerance: ±0.4 (Unless Otherwise Specified)

# DG シリーズ

## DG Series

### ■ 外形寸法 (mm) / Dimensions (mm)

形名及び型番号  
Type

DG11-B1RA

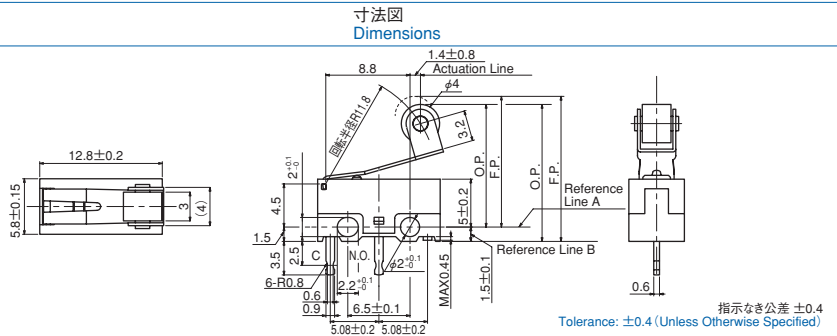
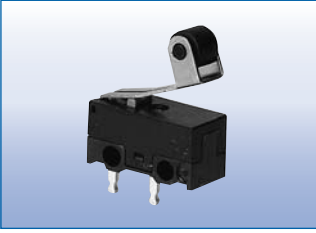

DG12-B1RA

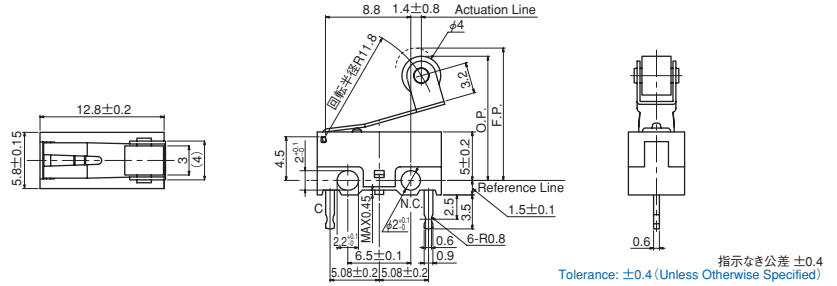
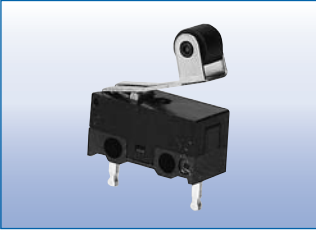

DG43-C1RA

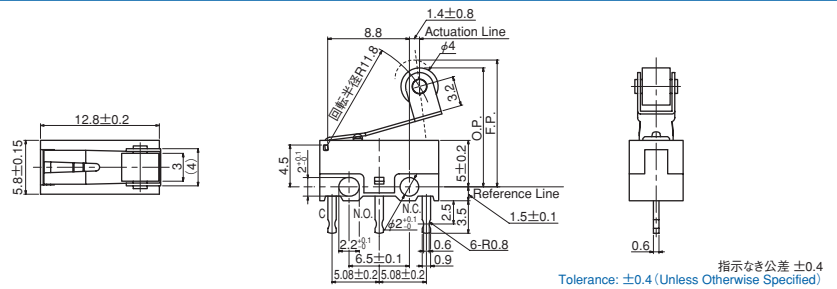
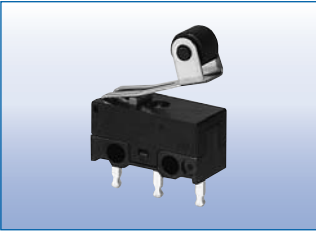

DG23-B1LC

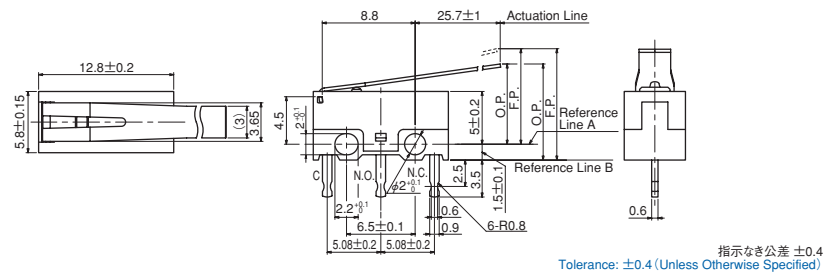
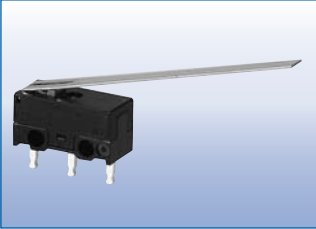

DG13-B2RA

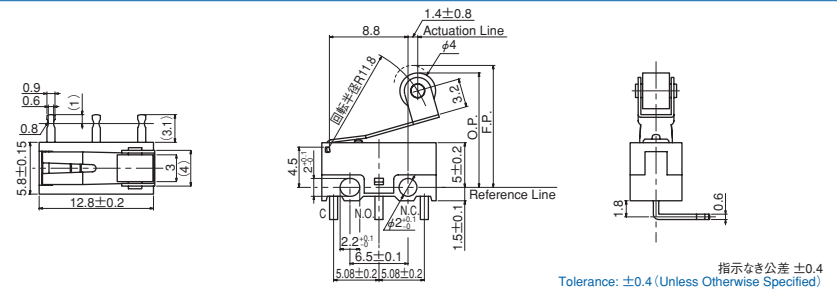

DG13-B3RA

