

# NESTOR MARTIN

## FH35 – RH35

### DIRECT VENT GAS STOVES INSTALLATION AND OPERATING INSTRUCTIONS

THERMIC DISTRIBUTION EUROPE  
5 VOIE AXIALE  
5660 COUVIN, BELGIUM



#### **WARNING**

If the information in this manual is not followed exactly, a fire or explosion may result causing property damage, personal injury or loss of life.

Do not store or use gasoline or other flammable vapors and liquids in the vicinity of this or any other appliance.

#### **WHAT TO DO IF YOU SMELL GAS:**

- Open windows
- Do not try to light any appliance.
- Do not touch any electrical switch; do not use any phone in your building.
- Immediately call your gas supplier from a neighbor's phone. Follow the gas supplier's instructions.
- If you cannot reach your gas supplier, call the fire department.

Installation and service must be performed by a qualified installer, service agency or the gas supplier.

**INSTALLER:** Leave this manual with the appliance.  
**CONSUMER:** Retain this manual for future reference.

## SAFETY PRECAUTIONS

For safe installation and operation of your NESTOR MARTIN stove, please, carefully read the following information:

- All NESTOR MARTIN gas fired appliances must be installed in accordance with these instructions. Carefully read all the instructions in this manual first. Consult the building authority having jurisdiction to determine the need for a permit prior to commencing the installation.
- Note: failure to follow these instructions could cause a malfunction of the fireplace which could result in death, serious bodily injury, and/or property damage.
- Failure to follow these instructions may also void your fire insurance and/or warranty.
- Installation and repair should be done by a qualified service person. The appliance should be inspected before use and at least annually by a qualified service person. More frequent cleaning may be required due to excessive lint from carpeting, bedding material, etc. it is imperative that control compartments, burners and circulating air passageways of the appliance be kept clean.
- Due to high temperatures the appliance should be located out of high traffic areas and away from furniture and draperies. Children and adults should be alerted to hazards of high surface temperatures and should stay away to avoid burns or clothing ignition.
- Young children should be carefully supervised when they are in the same room as the appliance.
- Clothing or other flammable material should not be placed on or near the appliance.
- Installation must conform with local codes or, in the absence of local codes, with the ANSI Z223.1 and CSA B149.1
- To prevent injury do not allow anyone who is unfamiliar with the operation to use the stove.
- These appliances should not be used as a drying rack for clothing or for hanging Christmas stockings or decorations.
- Due to the paint curing on the stove a faint odor and slight smoking will likely be noticed when the stove is first used. Open a window until the slight smoking stops. Always connect this gas stove to a chimney and vent to the outside of the building envelope. Never vent to another room or inside a building. Make sure you use the vent pipe that is specified. Make sure that the vent is properly sized and is of adequate height to provide the proper draft. Inspect the venting system annually for blockage and any signs of deterioration.
- Do not operate with cracked or broken glass. Under no circumstances should this appliance be modified. Parts that have to be removed for servicing must be replaced prior to operating this appliance. Only parts supplied by NESTOR MARTIN should be used in this appliance and replacements should only be performed by a licensed or qualified service person.
- Never use solid fuels such as wood, paper, cardboard, coal, or any other flammable liquids etc., in this appliance.
- Do not use this heater if any part has been under water. Immediately call a qualified service technician to inspect the heater and to replace any part of the control system and any gas control which has been under water.
- Do not abuse glass by striking or slamming door shut.

## PRODUCT SPECIFICATIONS

Gas type	Inlet supply pressure		Manifold pressure		Input		Pilot orifice size	Burner orifice size (mm)
	Minimum (inch WC)	Maximum (inch WC)	Minimum (inch WC)	Maximum (inch WC)	Minimum (BTU/h)	Maximum (BTU/h)		
Natural	7"	14"	2.6"	3.75"	34,000	42,000	272	4 x 1.54
Propane	11"	14"	5.7"	9.5"	30,000	40,000	221	4 x 0.96

For installation above 2000 feet:

- In Canada, these appliances are certified for altitudes of 0-2,000' and must be de-rated by 10% for installation at elevations between 2,000 and 4,500'.
- In the USA, the appliance must be de-rated 4% for every 1,000' above 2,000' elevations.

Gas control inlet: 3/8" NPT

Flue pipe outer diameter: 6 5/8"

Variable output gas control: Mertik Maxitrol GV60

Pilot: Mertik Maxitrol G30-ZP1

These appliances have been tested by CSA and found to comply with the established standards for direct vent gas fireplaces and in Canada and the USA as follows:

LISTED GAS FIRED GRAVITY DIRECT VENT WALL FURNACE (EG.95.FS.DV.Nat. & LPG)  
TESTED TO: ANSI Z21.886-2003/CSA 2.336-2003 STANDARDS

Direct Vent Type is designated by the suffix DV. This type of appliance draws all of its air for combustion from outside of the dwelling through specially designed vent pipe.

This fireplace requires ventilation and combustion air to operate properly.

This appliance is only for use with the type of gas indicated on the rating plate. A conversion kit is supplied with the appliance.

- Certified for use with either natural or propane gases (see appropriate labeling).
- Not for use with solid fuels
- Approved for bedrooms
- Must be installed in accordance with local codes, if any. If none exist use current installation code CAN/CGA B149.1 in Canada or ANSI Z223.1/NFPA 54 in the USA
- Mobile home approved: This appliance must be installed in accordance with the current standards – Canada CSA Z240.4; USA manufactured home construction and safety standard title 24 CFR, Part 3280.
- May be installed in an aftermarket permanently located, manufactured (mobile) home, where not prohibited by local codes.
- Must be properly connected to a venting system
- Not approved for closet or recessed installations

The efficiency rating of this appliance is a product thermal efficiency rating determined under continuous operating conditions and was determined independently of any installed system.

This appliance may be installed in an aftermarket, permanently located, manufactured home (USA only) or mobile home, where not prohibited by local codes.

This appliance is only for use with the type of gas indicated on the rating plate. This appliance is not convertible with other gases, unless a certified kit is used.

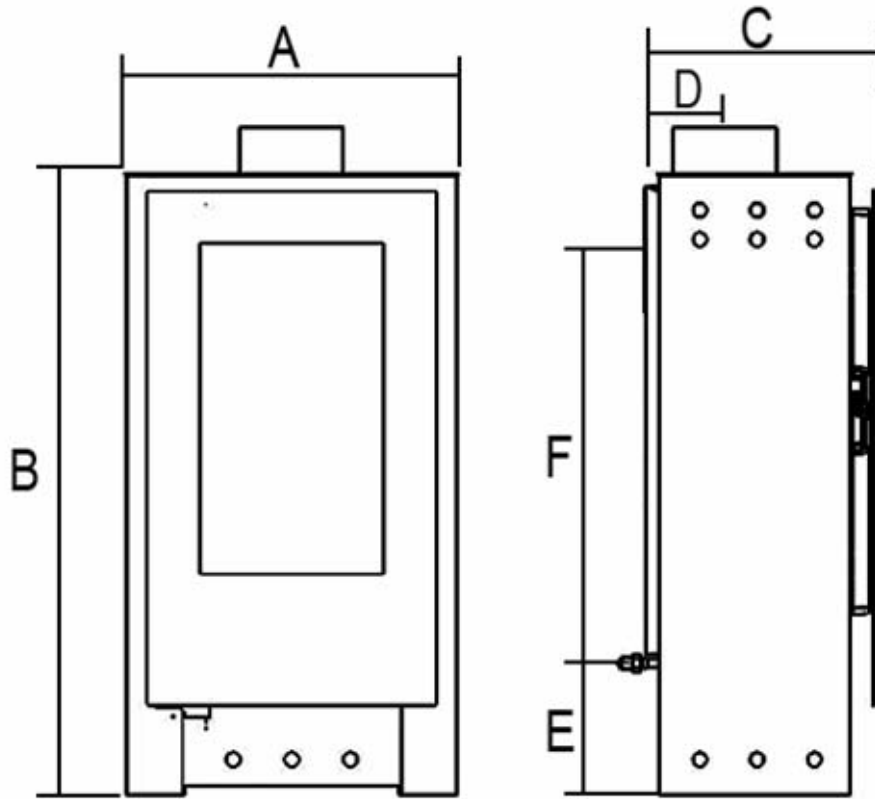
**STOVE DIMENSIONS**

	A	B	C	D	E	F
<b>FH35</b>	22½"	41⅞"	15½"	5½"	8⅞"	36⅝"
<b>RH35</b>	22½"	41⅞"	17"	5½"	8⅞"	36⅝"

# INSTALLATION

## DECIDING WHERE TO LOCATE YOUR STOVE

1. The stove should be located out of traffic and away from furniture and draperies.
2. This stove should have sufficient access for its safe operation and maintenance.
3. Locate a position where the flue system of the stove can be properly installed without damaging the integrity of the building. e.g. cutting wall or ceiling joists.
4. When the appliance is installed directly on carpeting, tile or other combustible material other than wood flooring, the appliance shall be installed on a metal or wood panel extending the full width and depth of the appliance.
5. Check stove and flue system clearance requirements.
6. Locate the stove where it can be accessed by a gas supply line.
7. Locate the stove in a large and open room that is centrally located in the house. This will optimize heat circulation and comfort.
8. This stove can be installed in bedrooms.
9. The flow of combustion and ventilation air must not be obstructed.

## MINIMUM CLEARANCES TO COMBUSTIBLES

- A – From side wall to stove: 6"  
 B – From rear wall to stove: 6"  
 C – Corner clearance: 6"  
 From top of stove to combustible: 36"  
 From front of stove to combustible: 60"

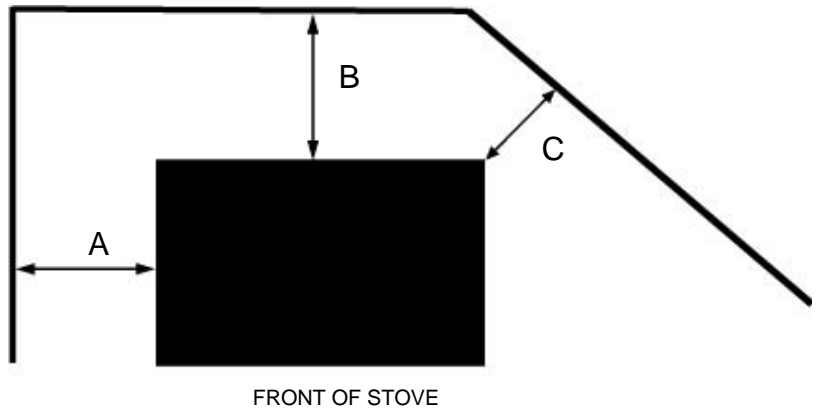

## FLOOR PROTECTION

The stove must be installed on rigid flooring. When the stove is installed on any combustible surface other than wood flooring, a metal or wood panel extending the full width and depth of the unit must be used as a hearth. There are no other hearth requirements.

### **WARNING:**

- Always maintain required clearances to nearby combustibles to prevent fire hazard. Do not fill air spaces with insulation. All venting components must maintain a 1" (25mm) clearance to combustible materials.
- The appliance and vent system must be vented directly to the outside of the building and never be attached to a chimney serving a separate solid fuel or gas-burning appliance. Each direct vent appliance must use its own separate vent system. Common vents are prohibited.
- Refer to the manufacturer's instructions included with the venting system for complete installation procedures.

## LOCATION OF THE VENT TERMINAL

The vent terminal must be located observing the minimum clearances shown on pages 6 and 7.

## VENT TERMINAL CLEARANCES

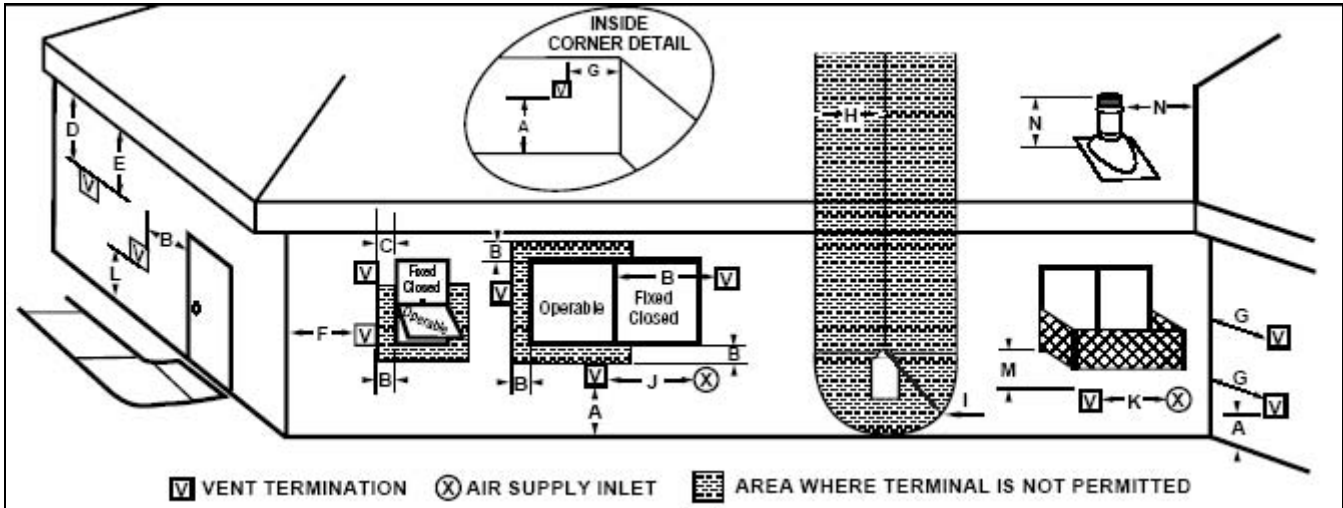

	Installations in Canada <sup>1</sup>	Installations in the United States <sup>2</sup>
A = Clearance above grade, veranda, porch, deck, or balcony	12" (30cm)	12" (30cm)
B = Clearance to window or door that may be opened	12" (30cm)	9" (23cm)
C = Clearance to permanently closed window	12" (30cm)	12" (30cm)
D = Vertical clearance to ventilated soffit located above the terminal within a horizontal distance of 2' (61cm) from the center line of the terminal	18" (46cm)	18" (46cm)
E = Clearance to unventilated soffit	12" (30cm)	12" (30cm)
F = Clearance to outside corner	6" (15cm) if combustible 2" (5 cm) if non-combustible	6" (15cm) if combustible 2" (5 cm) if non-combustible
G = Clearance to inside corner	6" (15cm) if combustible 2" (5 cm) if non-combustible	6" (15cm) if combustible 2" (5 cm) if non-combustible
H = Clearance to each inside of center line extended above the meter/regulator assembly	3' (91cm) within a height of 15ft extended above meter/regulator assembly	3' (91cm) within a height of 15ft extended above meter/regulator assembly
I = Clearance to service regulator vent outlet	3' (91cm)	3' (91cm)
J = Clearance to non-mechanical air supply inlet to building or the combustion air inlet to any other appliance	12" (30cm)	9" (23cm)
K = Clearance to a mechanical air supply inlet	6' (1.83m)	3' (91cm) above if within 10' (3m) horizontally
L = Clearance above paved sidewalk or paved driveway located on public property	7' (2.13m) <sup>†</sup>	7' (2.13m) <sup>†</sup>
M = Clearance under veranda, porch, deck or balcony	12" (30cm) <sup>‡</sup>	12" (30cm) <sup>‡</sup>
N = Clearance above a roof shall extend a minimum of 24" (61cm) above the highest point when it passes through the roof surface, and any other obstruction within a horizontal distance of 18" (45cm).		

<sup>1</sup> In accordance with the current CSA-B149.1 Installation Codes

<sup>2</sup> In accordance with the current ANSI Z223.1/NFPA 54 National Fuel Gas Codes

<sup>†</sup> A vent shall not terminate directly above a sidewalk or paved driveway which is located between two single family dwellings and serves both dwellings

<sup>‡</sup> only permitted if veranda, porch, deck or balcony is fully open on a minimum 2 sides beneath the floor:

NOTE: Local codes or regulations may require different clearances.

**Important Note: Vent terminals cannot be recessed into a wall or siding**

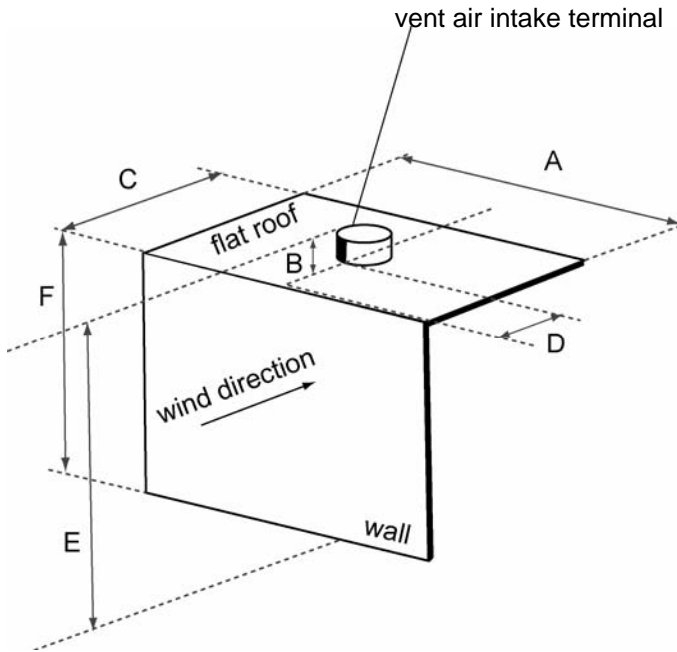
**SPECIAL CLEARANCES FOR VERTICAL VENTING (THROUGH A FLAT ROOF)**

Minimum clearances for vertical terminals	
A	4'
B	2'
C	4'
D	2'
E	8'
F	4'

**VENTING**

Your stove is approved for different types of installations:

- A. Top flue outlet with side wall venting (using a Simpson Duravent type terminal)
- B. Rear flue outlet with side wall venting (using a Simpson Duravent type snorkel)
- C. Top flue outlet straight through the roof (using a Simpson Duravent type chimney cap)

In each type of installation, it is essential to respect the minimum clearances to combustibles. It is recommended that a bead of RTV High Temperature Silicone be applied to each vent joint.

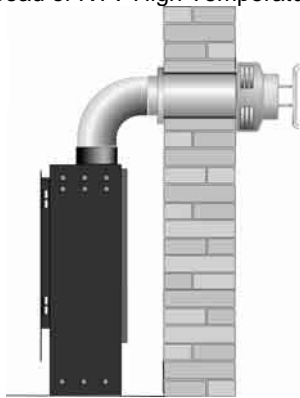
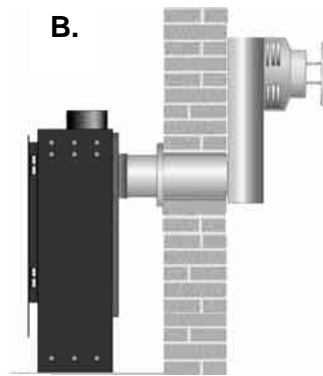
**A.****B.****C.**

### **Notes on Side Wall Venting with Top Flue (Configuration A)**

When installing a stove with a side wall venting configuration (page 6, fig. A), respect a ratio of one quarter inch rise for every 2 feet horizontal. The minimum vertical rise allowed is 2 feet (measuring from the top of the stove's flue collar to the bottom edge of the 90° knee. The minimum horizontal run is also 2 feet (measuring from the outer edge of the 90° knee to the inner edge of the termination cap. Use a Simpson Duravent type termination cap. See table below for possible horizontal to vertical ratios.

Follow the vent pipe manufacturer's instructions for assembly and installation.

CAUTION: VENTING TERMINALS CANNOT BE RECESSED INTO A WALL OR SIDING.

### **Vertical/Horizontal Vent Pipe Ratios**

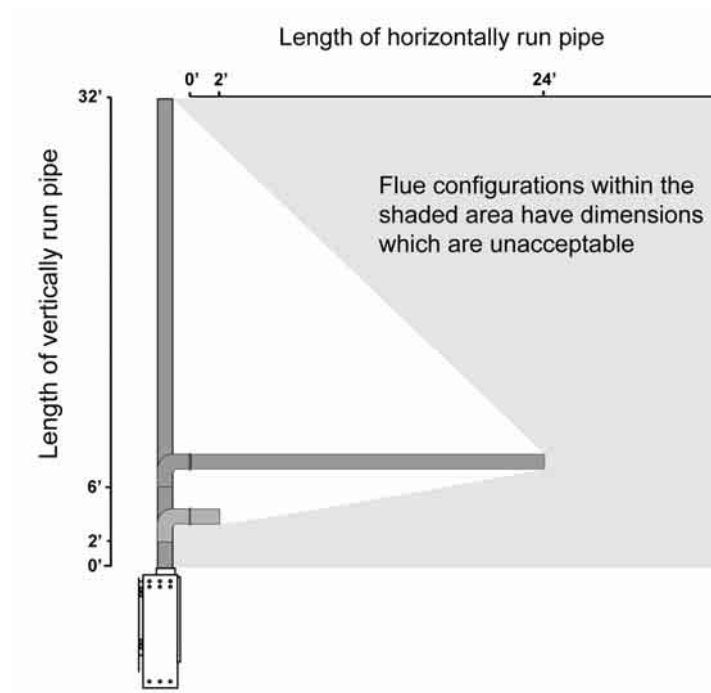

Note:

- The horizontal termination must not be recessed into the exterior wall or siding.
- Horizontal vent runs must be level toward the vent termination.
- Clearances around the vent termination must be maintained.

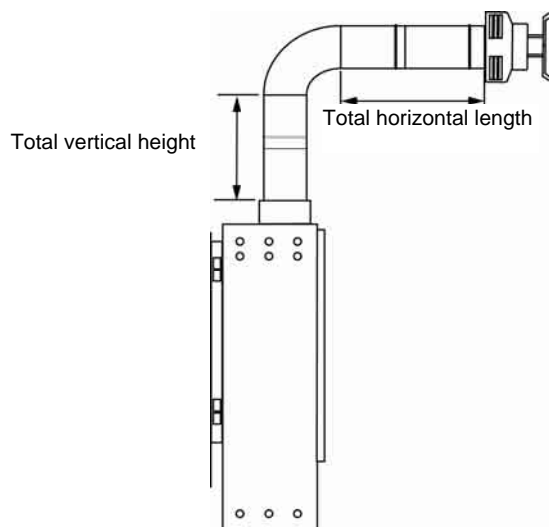



**RESTRICTION PLATE**

A set of restriction plates is supplied with your stove to reduce flue draft when required.



74mm (2 $\frac{7}{8}$ " ) restriction plate

The reduction plate is to be used in the following vent configurations:

**Top flue exit**

	<b>2' vertical rise, 2' horizontal length</b>	<b>6' vertical rise, 24' horizontal length</b>
<b>Natural Gas</b>	Use 74mm (2 $\frac{7}{8}$ " ) restriction plate	Use 74mm (2 $\frac{7}{8}$ " ) restriction plate
<b>Propane</b>	Use 74mm (2 $\frac{7}{8}$ " ) restriction plate	No restriction plate required

Install the restrictor plate directly at the stove outlet as follows:

1. Unscrew and remove the cast iron flue collar.
2. Unscrew and remove the inner flue outlet as well as the gasket.
3. Place the restriction plate on the stove's inner firebox so that it reduces the exhaust outlet diameter.
4. Replace gasket and inner flue collar and fasten using the four screws.
5. Finally, replace the cast iron flue collar.

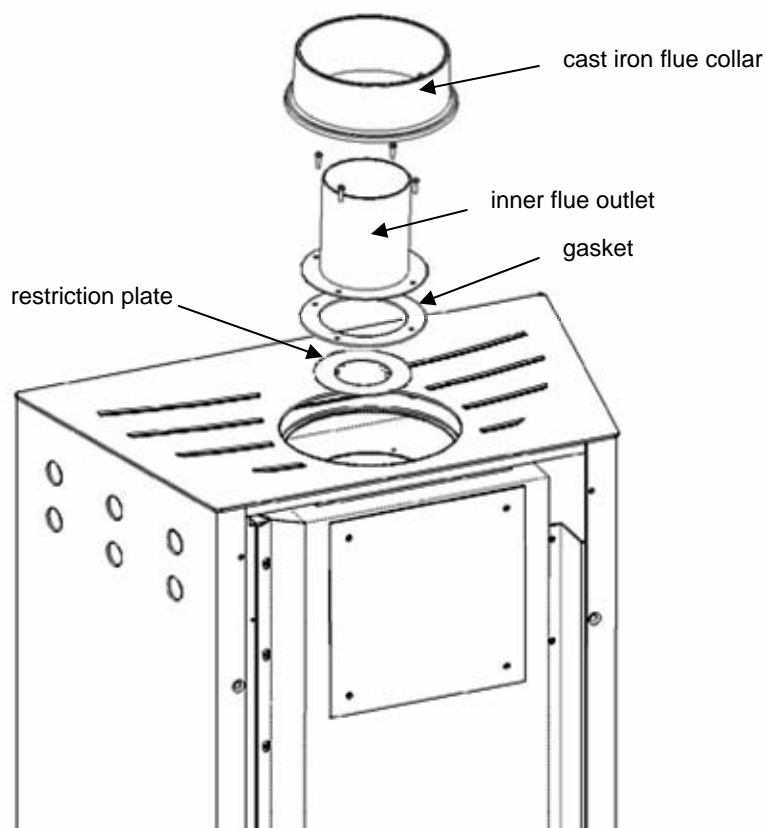

## **CERAMIC BURNER**

Your stove is equipped with a 100% ceramic fiber gas burner. Nestor Martin's ceramic burner offers numerous technical and esthetic advantages:

- Flames and glowing effect similar to a real wood fire
- Highly resistant to leaks, corrosion and deformation over time
- The elasticity of its gel foam ceramic fibers allow the burner to retain its heat resistant properties without deforming, withstanding even the most extreme temperature variations.
- Increased radiant heat through the glass, while greatly decreasing radiant heat on the valve, receiver and battery, resulting in longer life for each of the stove's electronic components.

The burner has several positioning points and notches to help you place the ceramic logs correctly.

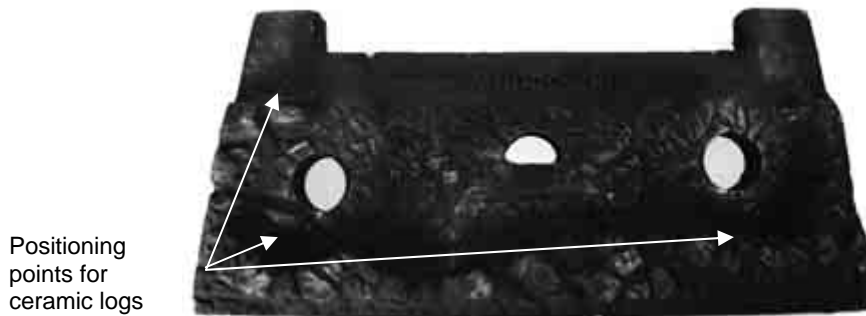

Ceramic burner

## **CONTENTS OF THE LOG KIT**

The kit is composed of three ceramic logs and a sack of ceramic lava rocks. Because they are fragile, the logs are packaged separately to avoid damage during transport. Using logs other than those supplied by the manufacturer is prohibited, as it may interfere with the proper functioning of the appliance.

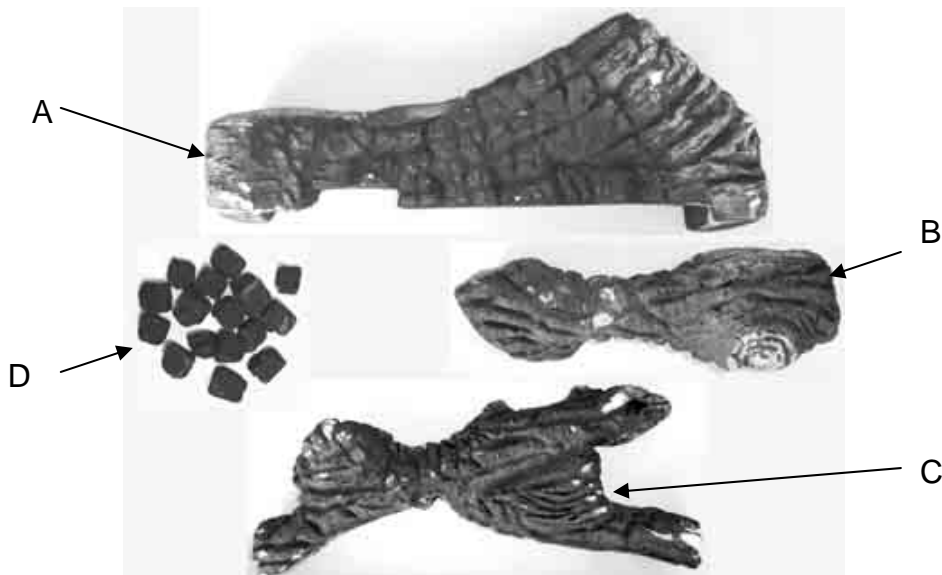

**PLACING THE CERAMIC LOGS**

Open the firebox door to access the burner, and place the logs as shown in the photos below. It is essential to the proper operation of the stove that the logs be placed correctly.

1



Place the lava rocks along the holes in the burner, leaving about 1" of space in between them.

2



Place log A onto the burner's rear positioning points.

3



Place log B on the left side of the burner, in the notches and leaning against log A.

4



Place log C at the front as shown, against the positioning points on the burner.

### **PLACEMENT OF THE EMBER GLOW FIBERS (OPTIONAL)**

A bag of platinum ember glow fibers is supplied with the ceramic burner kit. When heated, the embers glow and flicker, similar to real glowing ash. The embers must be placed correctly in order to function properly. The pack contains more embers than required. The remaining embers should be kept for further service requirements.

Platinum ember glow fibers are made from high-grade ceramic wool. The wool is similar to fiberglass and should be handled carefully. We recommend the use of a suitable dust mask, gloves or tweezers when handling the embers. Wash hands immediately after touching to avoid irritation. Store the fibers in a dry place, away from any flammable liquids.

Before placing, tease out the fabric to form loose, irregular shapes using a tweezers.



Tease out the fabric to form loose, irregular shapes. Do not compress the embers.

The correct placement of the embers is extremely important, as the effect produced can only occur when they are heated by the gas jets or by direct radiated heat. Do not force the embers into the burner holes, as to not block them up.

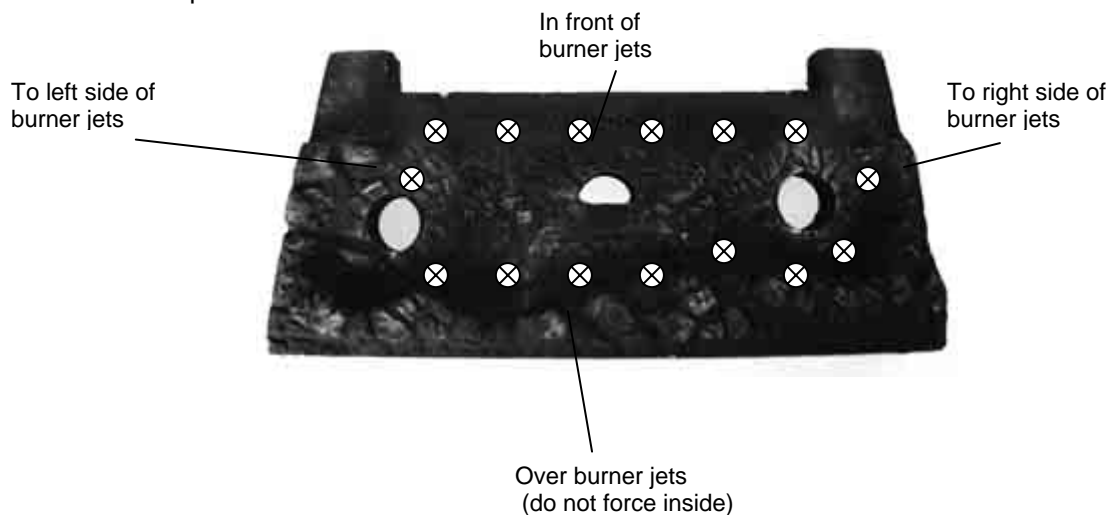

By rubbing the embers into the faces of the logs which are heated by the gas jets, the fibers which adhere to the logs will glow. With suitable gloves, gently rub a square of fibers into the areas of the logs which glow when hot.

**CONNECTING THE GAS SUPPLY LINE**

WARNING: Only persons licensed to work with gas piping may make the necessary gas connections to this appliance.

The gas line connection may be made using 3/8 " rigid tubing or an approved flex connector. When using copper or flex connectors, use only fittings approved for gas connections. The gas control inlet is 3/8" NPT. Upon connection, mark the appropriate fuel type on the CSA rating label.

There must be a gas shutoff between the stove and the supply.

Since some municipalities have additional local codes it is always best to consult your local authorities and the CAN/CGA-B149.1 Installation Code. For USA gas installations follow either local codes or the current edition of the National Fuel Gas Code ANSI.Z223.1.

Test to confirm manifold pressures as shown in the table on page 3.

The stove and its individual shutoff valve must be disconnected from the gas supply piping during any pressure testing of that system at test pressures in excess of 1/2 psi (3.5 kPa).

The stove must be isolated from the gas piping system by closing its individual shutoff valve during any pressure testing of the gas supply piping system at test pressure equal or less than 1/2 psi (3.5 kPa).

Always check for gas leaks with a mild soap and water solution. Do not use an open flame for gas leak testing.

## DESCRIPTION OF THE MERTIK MAXITROL GV60 GAS VALVE

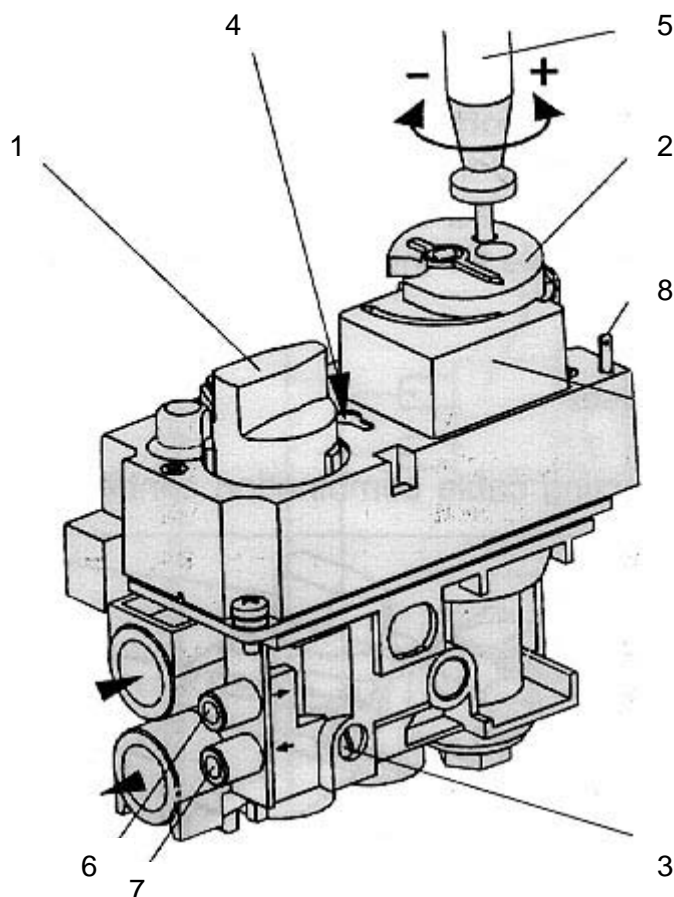

1. Min/Max control knob
2. Operation mode dial (for manual ignition)
3. Minimum rate adjustment screw
4. Maximum rate adjustment screw (remove plug first)
5. Pilot gas rate adjustment (with a screwdriver)
6. Inlet pressure tap
7. Burner pressure tap
8. Electric connector for piezo igniter (tab 2,8 x 0,8mm)

**- Adjusting the Maximum Manifold Pressure**

If the pressure to the burner is not equal to that indicated in the table on page 3, turn the adjustment screw #4 clockwise to decrease or counterclockwise to increase. Note: the gas valve is factory sealed for natural gas inlet pressure.

**- Adjusting the Minimum Manifold Pressure**

To adjust the minimum pressure to the burner, turn screw #3 clockwise to decrease or counterclockwise to increase.

**- Adjusting the Pilot Flame**

The pilot is pre-set at the factory for maximum. The adjustment screw (#5 on above diagram) can be reached through a hole in the Operation mode dial. Turn the dial to ON position. It is now possible to pierce through a film on the cover with a screw driver to reach the adjustment screw beneath. turn screw #5 clockwise to decrease or counterclockwise to increase.

# LIGHTING & OPERATING INSTRUCTIONS

## 1. MANUAL LIGHTING & OPERATION

### The Gas Valve

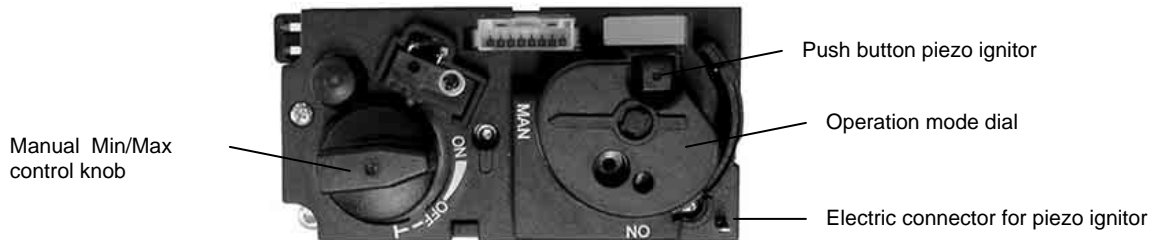

### Lighting the Pilot Manually

Ensure that the ignition cable is hooked up to the piezo connector

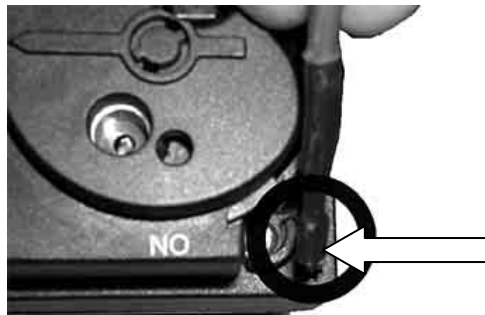

(NOTE: for use with the remote control, this cable must be connected to the receiver and not to the piezo connector).

Turn the gas valve switch to ON position (1) .

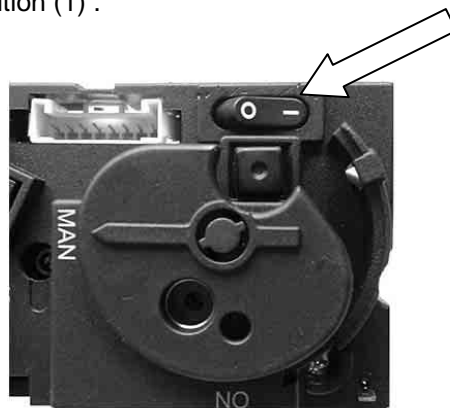

Turn the dial to "MAN" position. A metallic bushing is visible.

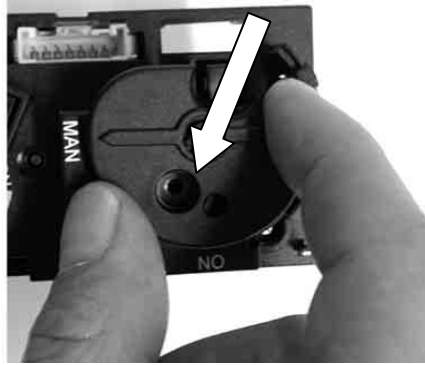

Push the bushing in using a pen (or other tool) to allow gas to flow to the pilot. While pushing the bushing in, press the piezo igniter button several times to light the pilot. (note: if the piezo igniter is not connected, it is equally possible to light the pilot with a match).

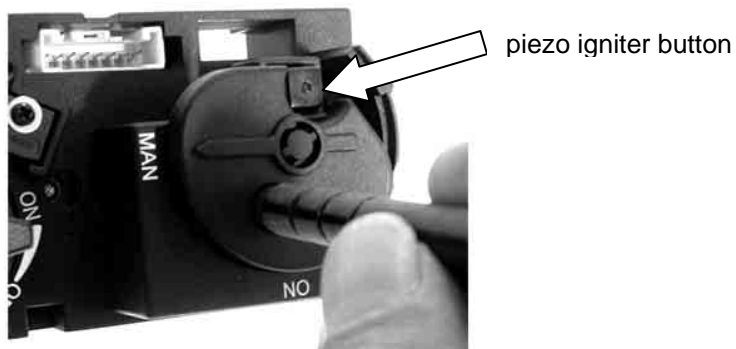

Hold the bushing down for another 10 seconds. Repeat the lighting procedure if the pilot does not stay lit. If the piezo igniter does not produce a spark, verify the connections as well as the spark plug.

Once the pilot is lit, release the bushing and turn the dial to "ON" position.

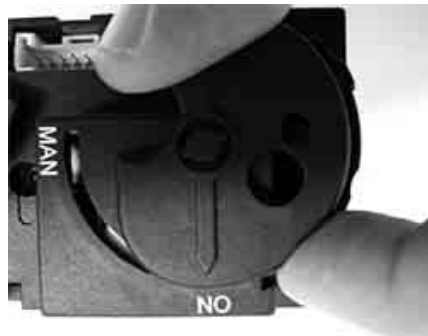

**Lighting the Burner Manually**

Turn the manual control knob to light the burner and adjust to the desired flame height.

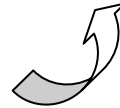
**Extinguishing the Burner Manually**

Turn the manual control knob counter-clockwise to the "OFF" position to extinguish the burner and put the stove in pilot mode. The pilot can remain lit while the stove is not in use, thereby allowing for easy relighting.

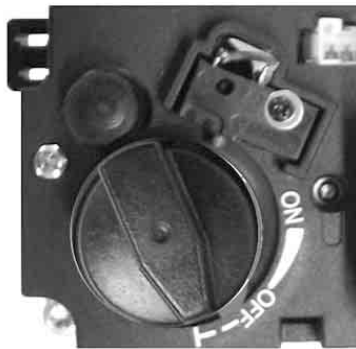
**Extinguishing the Pilot**

If you plan to not use the stove for a prolonged period of time, turn the switch to the OFF position ("0") to extinguish the pilot flame.

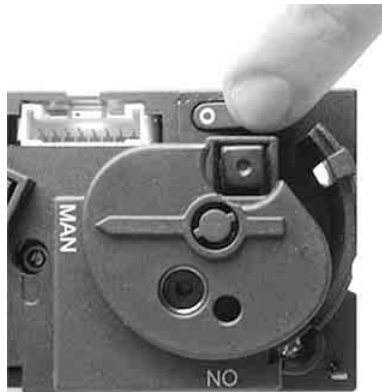

## 2. LIGHTING & OPERATION WITH REMOTE CONTROL

### Mertik Maxitrol G6R-H3 Remote Control

CAUTION: Read the instructions carefully before use. The G6R-H3 remote kit must be installed and operated according to all applicable regulations.

#### Components of the G6R-H3 kit:

Remote Control Handset  
(with integrated thermostat)



Receiver

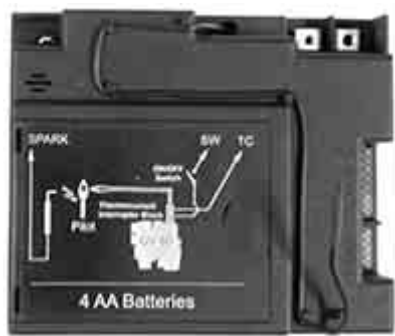

Wire Assembly

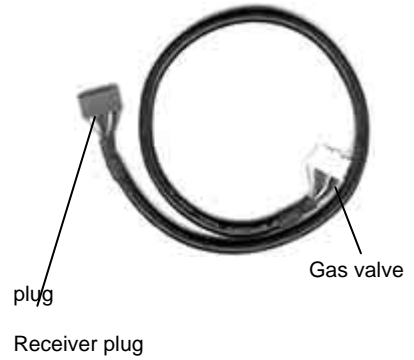

#### Technical Data

Radio Frequency  
Operating Range  
Max. Ambient Temperature

Batteries

Complies with part 15 of the FCC Rules.

Remote Handset and Receiver  
Wiring  
Remote Handset  
Receiver

315 MHz for US and Canada  
3'-33' (1-10m)  
(140°F) 60°C  
(356°F) 180°C  
1 x 9 V block  
4 x 1.5 V (AA)

#### Connections

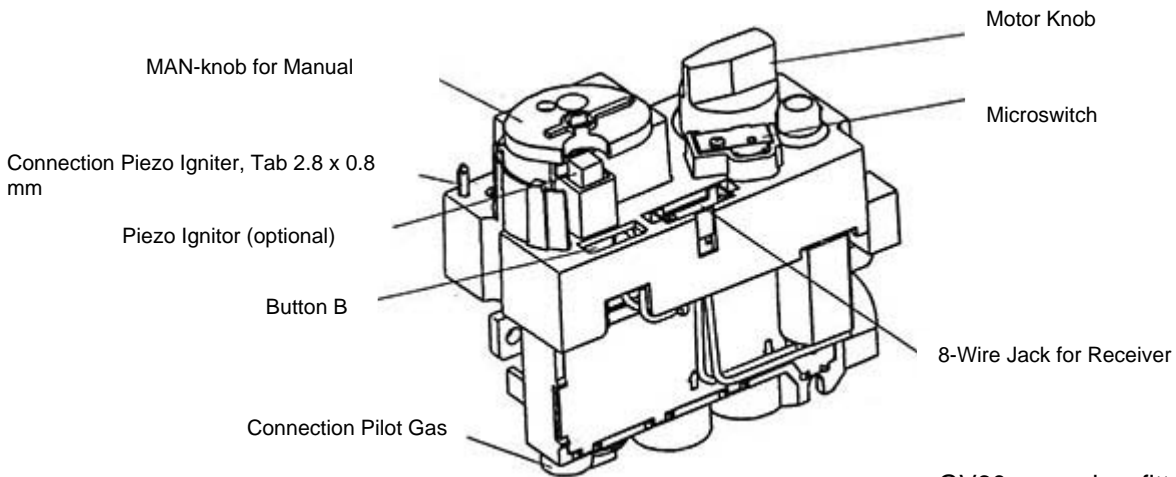

GV60 gas valve, fitted with connections for the G6R-H3 remote control kit.

## Using the Remote Handset

The remote control can be used in three different modes of operation: **Manual Mode**, **Thermostatic Mode** and **Timer Mode**

**Manual:** In Manual mode, all adjustments to the tempo of the fire are made using the ▲ and ▼ buttons.

**Thermostatic:** in Thermostatic mode, all adjustments to the tempo of the fire are made automatically to maintain the programmed temperature. It is possible to set a daytime temperature and a nighttime temperature.

**Timer:** in Timer mode, all adjustments to the tempo of the fire are made automatically and in periods. It is possible to set two desired temperatures as well as the hours of your stove's operating cycles. This is convenient if, for example, you would like 65°F between 7am and 3pm, and then 72°C between 6pm and 6am.

Even if you use your remote in Timer mode, you can always make manual adjustments to the flame height by using the ▲ and ▼ buttons.



### Setting the Display Type

- Press OFF and ▼ simultaneously until the display changes from °F (and 12 hour clock) to °C (and 24 hour clock), or vice versa.

### Setting the Time

- After connecting the battery, or by pressing ▲ and ▼ simultaneously, the display will begin to flash. You are in set mode.
- From set mode, press ▲ to set the hour and ▼ to set the minute.
- Wait 15 seconds or press OFF to save the setting and return to manual mode.

### Lighting the Stove with Remote Control

- Press ● and ▲ simultaneously. A beep sound confirms the beginning of the ignition sequence.
- If the pilot flame is already lit, the main burner can be ignited simply by pressing the ▲ button.

Note: You must wait at least 50 seconds after shutting the stove down before relighting. A security device is fitted which does not allow immediate relighting.

### Shutting Off the Main Burner

- Press and hold the ▼ button for a few seconds to switch off the main burner and go to standby pilot mode. Pilot mode allows for rapid relighting of the stove at the next use.

### Complete Shut Down (main burner and pilot)

- If you plan to not use the stove for a prolonged period of time, press OFF to switch off the main burner as well as the pilot flame.

### Changing the Mode of Operation

- Pressing the SET button quickly changes the mode of operation. You may choose between Manual (MAN), Daytime Temperature (☀TEMP), Nighttime Temperature (☾TEMP), or Timer (TIMER).

### Manual Flame Height Adjustment

- Press ▲ to increase flame height. MAN appears on the display, indicating that you are in manual mode.
- Press ▼ to decrease flame height.
- A symbol indicating transmission 𐄂 appears on the display when one of these buttons are pressed. The receiver acknowledges the transmission with an acoustic signal.
- Short tapping of either button allows incremental change in flame height.

**Setting the Desired Temperature**

- Press SET to select the desired mode of operation: Daytime Temperature (☼TEMP) or Nighttime Temperature (☾TEMP).
- Press and hold SET until the display flashes.
- Use the ▲ and ▼ buttons to set the desired temperature.
- Wait about ten seconds or press OFF to confirm your setting and return to temperature control mode.
- Note: If you want the stove to switch off at night, press ▼ until -- appears on the display.

**Setting the Timer**

- The timer allows you to set specific times for on and off. There are two burner cycles on and two burner cycles off every 24 hours. If the nighttime setting is --, the stove will go into standby pilot position and await the next "on" cycle.
- Switch to TIMER mode by pressing the set button briefly.
- Press the SET button until P1☼ flashes on the display. (P1☼ indicates daytime period 1)
- Set the time for the start of the first daytime heating period, using ▲ to change the hour and ▼ to change the minute.
- Press TIMER again; the P1☾ symbol appears on the display (P1☾ indicates nighttime period 1)
- Set the time for the start of the first nighttime heating period, using ▲ to change the hour and ▼ to change the minute.
- Now press TIMER to program the second daytime period (P2☼) and the second nighttime period (P2☾).
- Save your settings by pressing TIMER once more.
- If you wish to have only one heating period, set the same time for P1☼ et P2☼.

**Checking the Temperature While in Automatic Mode.**

- If your remote is operating in thermostatic mode (TEMP), you can always check the temperature setting.
- Press the SET button once. The set temperature appears on the display.
- After about ten seconds, the display will revert back to the current ambient temperature.

**Note on Batteries**

- To prolong battery life, switch to Manual mode by pressing ▼ before shutting down your stove. If the remote control is left in Thermostatic or Timer mode, the batteries will continue working even while the stove is completely extinguished.
- If the BATT symbol appears on the display, or if the display becomes less visible, change the batteries in the remote handset or in the receiver.

**Notes**

The location of the remote handset is an important factor in ensuring correct temperature adjustment in the stove. Generally, a more consistent room temperature can be obtained by placing the remote handset not too far from the stove. Nevertheless, it is not recommended to use the remote handset at less than three feet from the stove, because in rare cases, this may cause an electrical communication error. This error could cause valve's control knob to get stuck. If this happens, simply turn the button manually to unstuck. In order for the TEMP and TIMER functions to operate correctly, the remote handset must be within its normal operating range (between 3 feet and 33 feet from the stove).

The temperature is controlled by the activation of a motor on the gas valve for a specific period to obtain the flame height necessary. This period is determined by the size of the room, ceiling height, the heating capacity of the stove, the type of gas, etc. Several cycles are necessary before the ideal period can be obtained. If a small flame is sufficient to heat your room to the set temperature, then the stove will change back and forth from a small flame to burner shut off. This allows longer for a more consistent temperature, as well as longer operating periods (when the flame is visible).

## MAINTENANCE

Before conducting any maintenance on the stove, always make sure that the stove is switched off and has had time to cool.

- **VENTING SYSTEM**

The venting system should be examined annually by a qualified technician. Both the inner exhaust pipe and the outer combustion supply pipe must be checked to confirm that they are unblocked and in good condition.

- **CLEANING OF GLASS**

Do not clean glass when hot.

It will be necessary to clean the ceramic glass periodically. During a cold start up condensation will sometimes form on the glass, this is a normal condition with all glass fireplaces and stoves. However sometimes this condensation can allow dust and lint to cling to the glass surface. Also, sometimes initial paint curing of the appliance can leave behind a slight film on the glass. This is a temporary problem. It is therefore recommended that the glass be cleaned initially after about the first two weeks of use.

After that, depending upon the amount of use, cleaning should be required no more than two or three times per season. To clean the door, use a mild glass cleaner and a soft cloth. Abrasive cleaners will damage the glass surface.

- **PILOT, BURNER AND FIREBOX**

Periodically check the pilot and burner flames visually.

Remove the log set carefully from the combustion chamber.

Vacuum the burner compartment thoroughly.

Vacuum any dust on the logs and remove any lint form the main burner and pilot burner.

After carefully replacing the logs in their correct positions, and the door has been released, relight the pilot, following the instructions on the attached label. And turn in the main burner.

## WARRANTY

NESTOR MARTIN guarantees the equipment against material defects and workmanship. This warranty is subject to the terms specified below. It gives you specific legal rights, you may also have other rights that vary from region to region.

The warranty is limited to parts replacement and does not include any labor allowance. Any service charges for parts replacement are your responsibility.

1 YEAR	5 YEARS
VALVE BURNER ENAMELLED PARTS	COMBUSTION CHAMBER

Exclusions :

- Rust due to condensation
- Noises due to dilatation or contraction during the ignition stage or extinction stage
- No warranty is offered on chipping or damage of enamel surfaces. Inspect your stove for damage to the enamel prior to reception.
- The warranty excludes the logs, thermocouple, gaskets, orifices and window glass.

All warranty service and/or replacement of parts must be performed for you by an individual or servicing company which has been authorised by NESTOR MARTIN distributors. You may avail of the benefits of warranty coverage on a failed part by having the servicing company replace the part and return it to the NESTOR MARTIN distributor for inspection. If the warranty covers the failure, the replacement part will be free of charge. Transport charges for shipment of the replacement part and return of the failed part are your responsibility. Any such warranty replacement or repair shall be subject to the terms and conditions of this warranty for the remainder of the original period of coverage.

This warranty does not cover any failures or operating difficulties due to accident, abuse, misuse, alteration, misapplication, improper installation or improper maintenance or service.

Any implied warranties of merchantability and fitness applicable to the equipment are limited in duration to the period of coverage of this express written warranty. Some states do not allow limitation on how long an implied warranty lasts, so this limitation may not apply to you.

NESTOR MARTIN IS NOT LIABLE for any special, indirect or consequential damages. Some states do not allow the exclusion or limitation of incidental or consequential changes, so this limitation or exclusion may not apply to you.

NESTOR MARTIN does not authorise any person or company to assume any other obligation or liability in connection with the sale, application engineering, installation, use, removal, return or replacement of its equipment; and no such representations are binding on NESTOR MARTIN.